

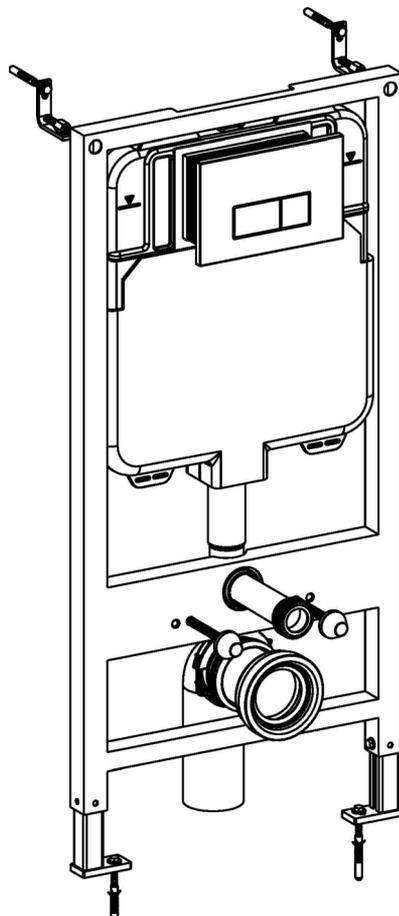

Инструкция по установке и монтажу для подвесного унитаза



Инструкция по установке инсталляции

Состав и комплектация

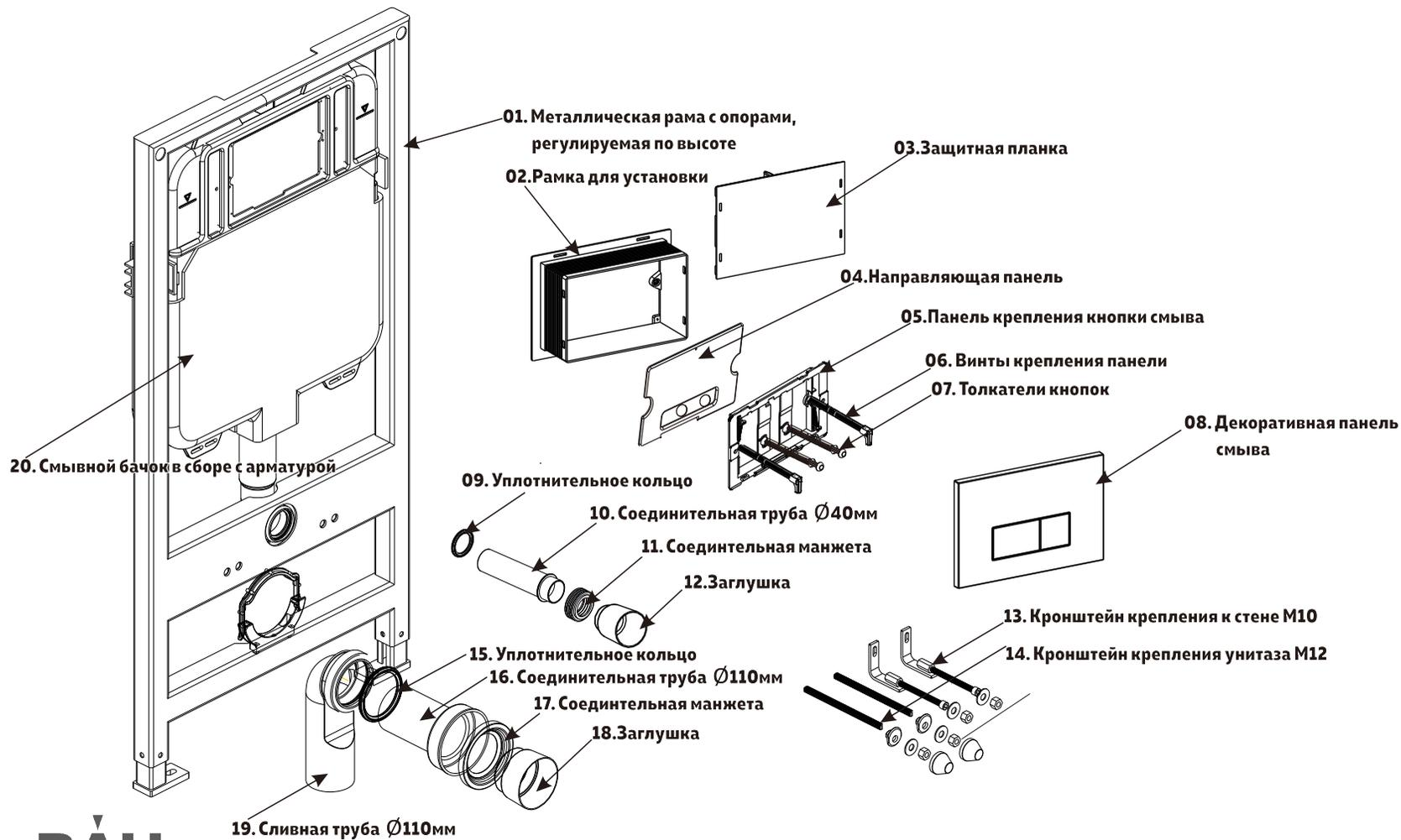

1. Технические размеры

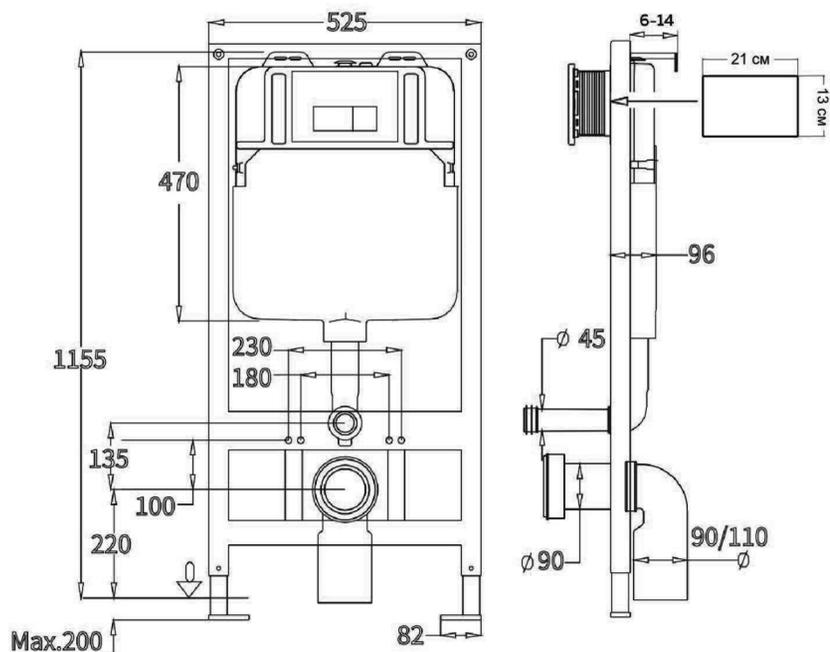

2. Способы крепления

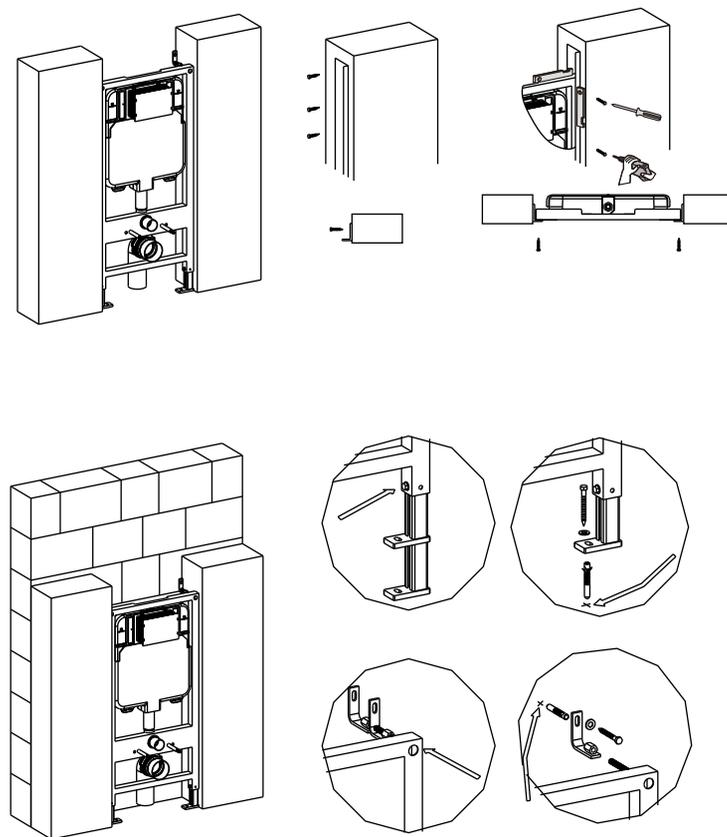

BAU
EDGE

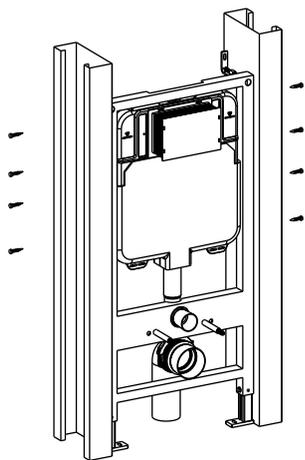
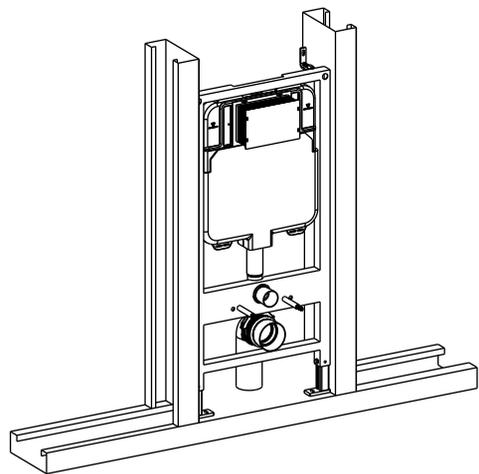

3. Подсоединение к канализации

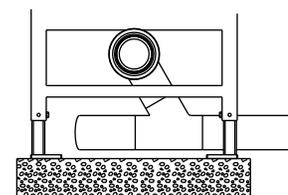
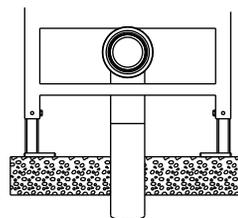
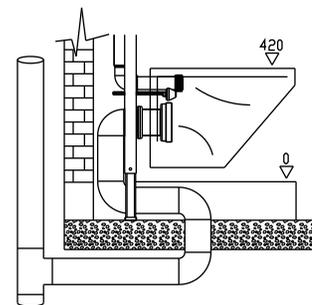
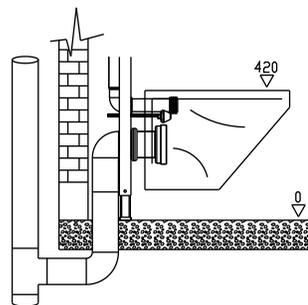
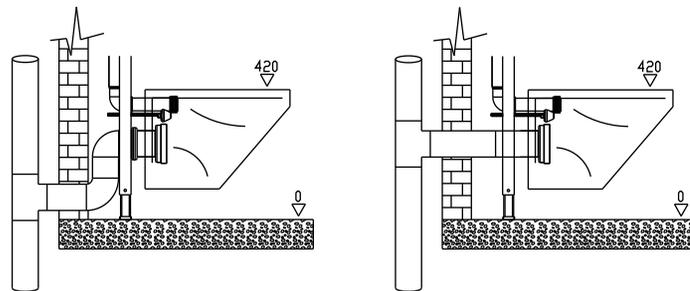

4. Подключение к сети холодного водоснабжения

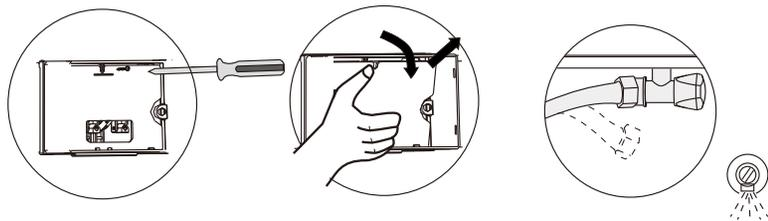
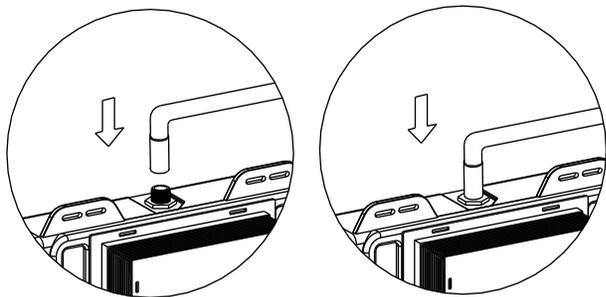

5. Подготовка перед монтажом

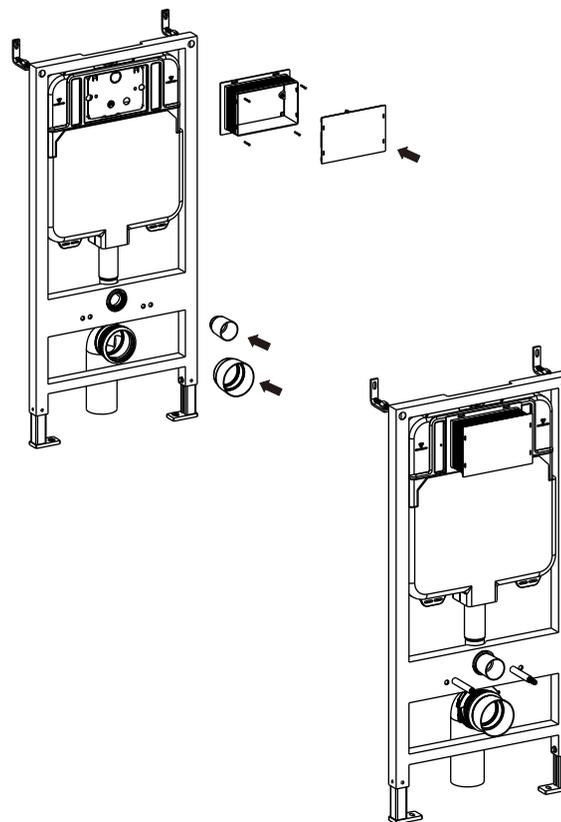

BÄU
EDGE

6. Отделка стены

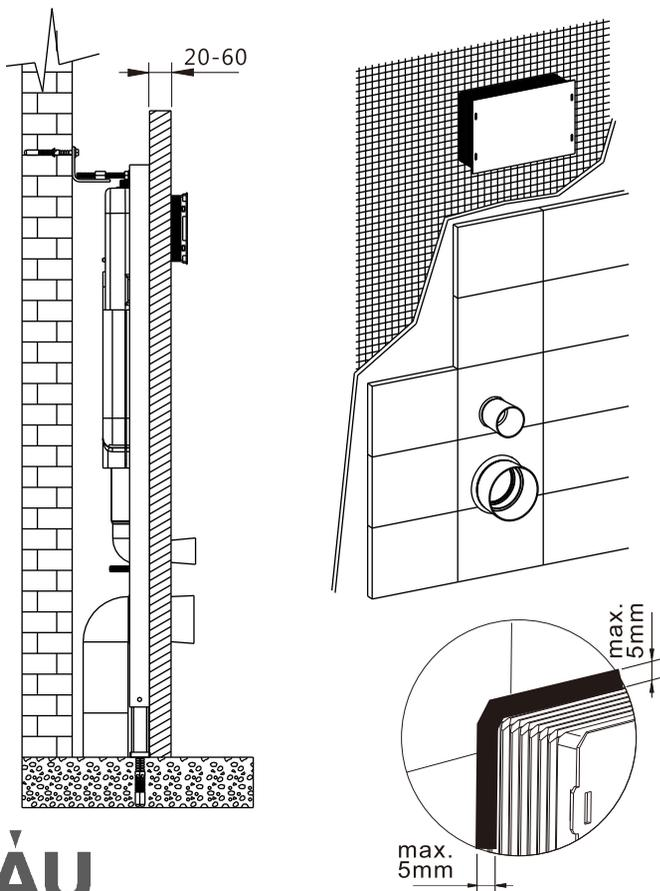

7. Установка присоединительных патрубков

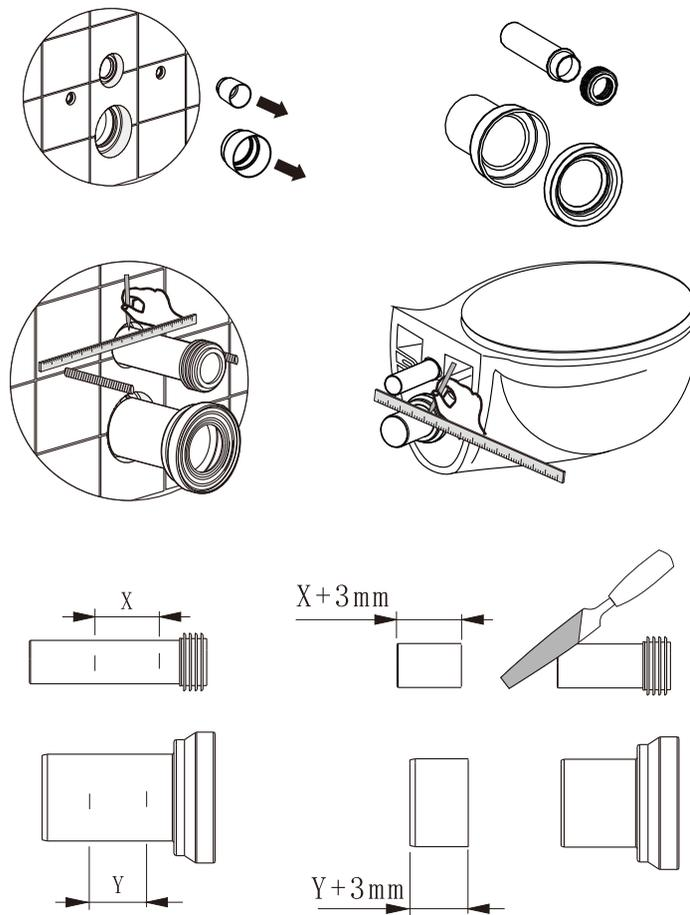

8. Установка унитаза

Элементы крепежа:

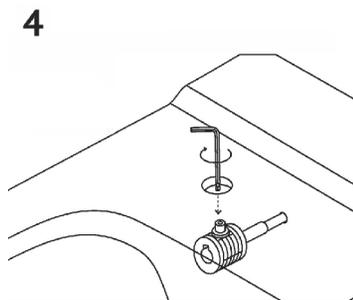
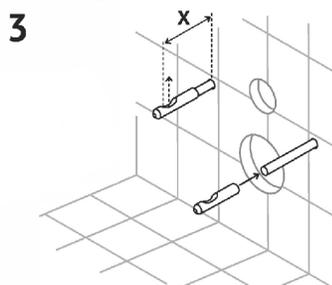
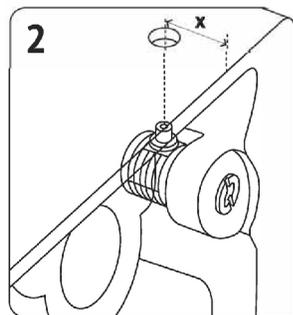
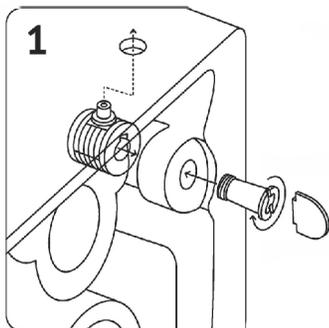

8. Установка панели смыва

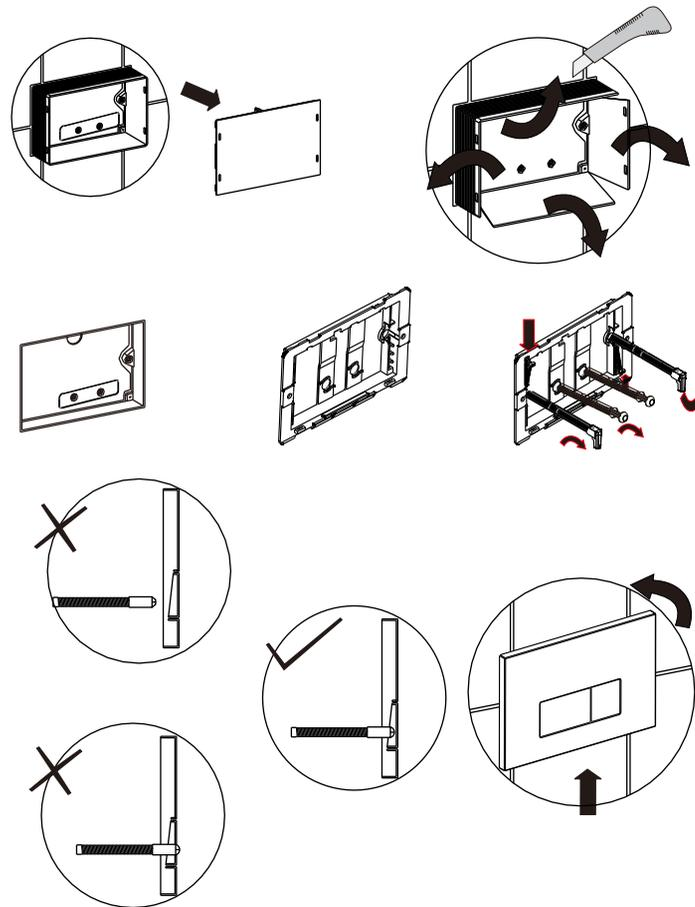

Техническое обслуживание

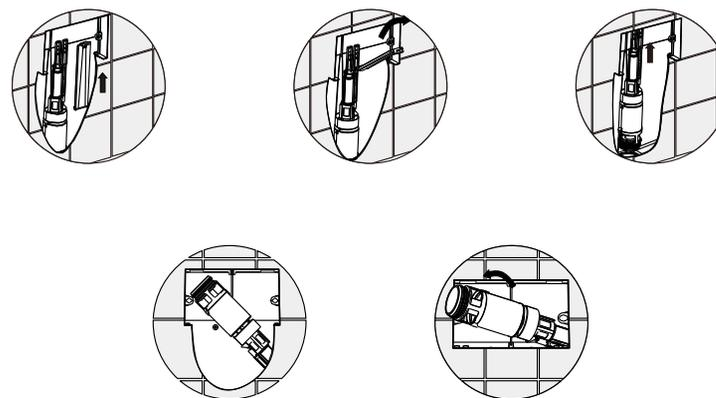
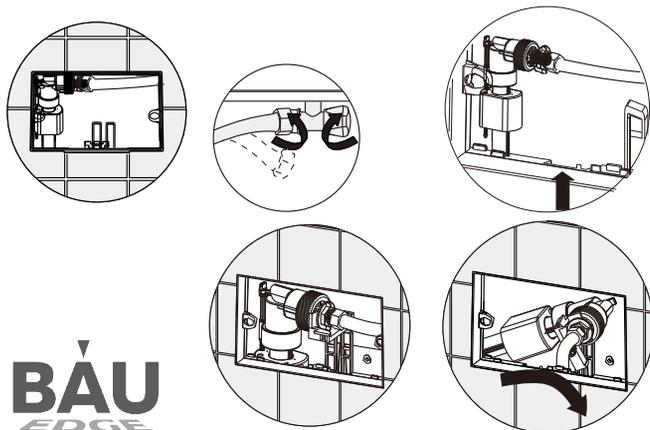
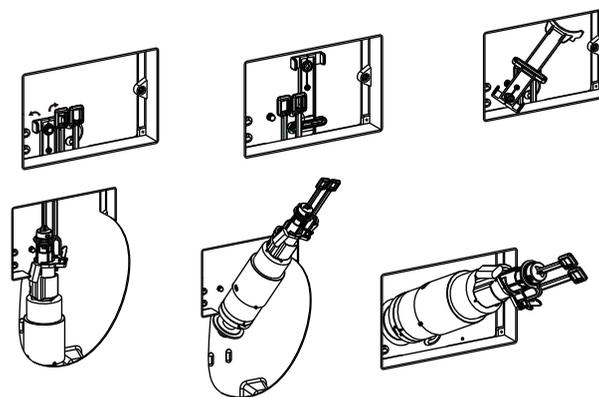
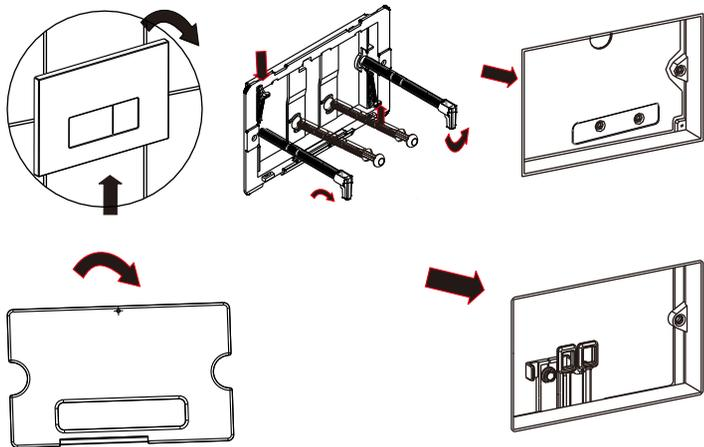

BAU
EDGE

1. Обслуживание наливной арматуры

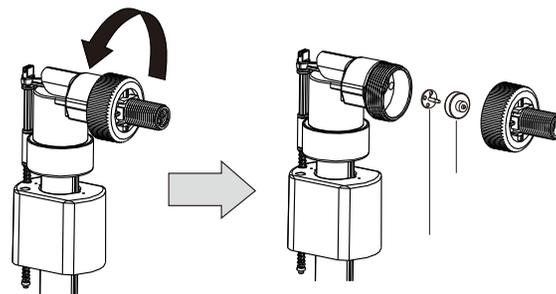
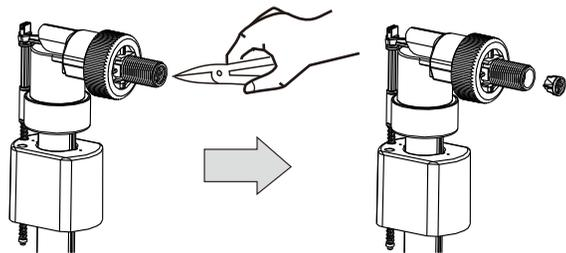
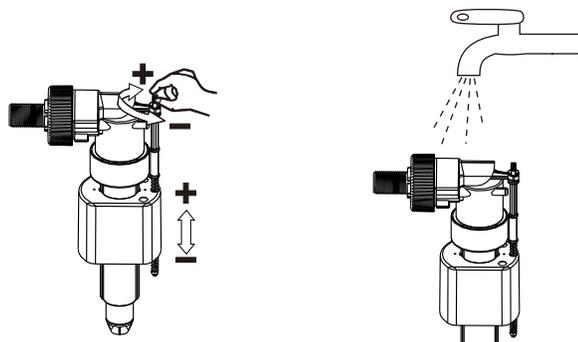

2. Обслуживание сливной арматуры

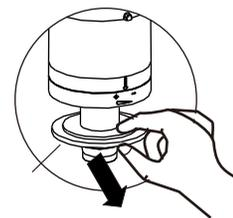
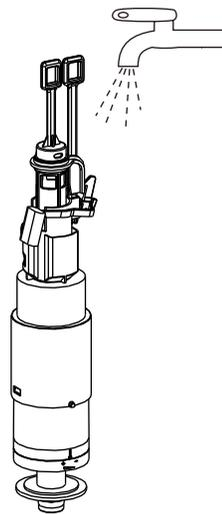
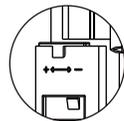
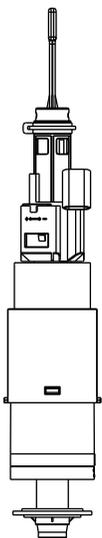
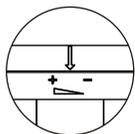
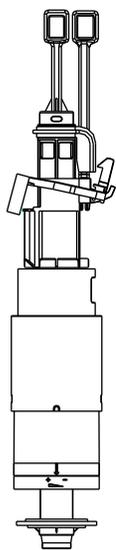

2. Обслуживание сливной арматуры

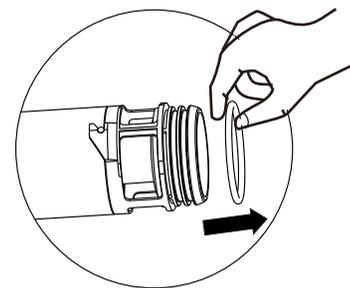
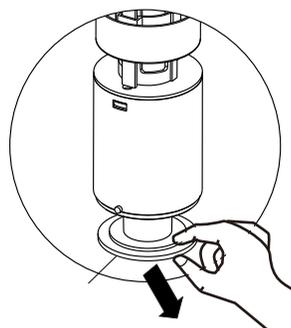
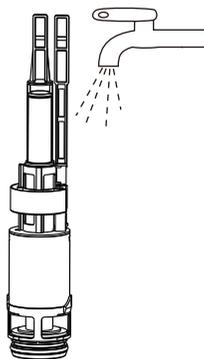
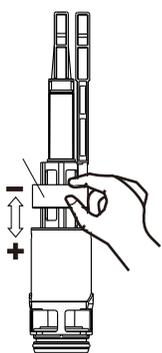

BÀU
EDGE

Everything for you